

TAPENER MAX

HT-R45C(RD), HT-R45L(OR)

INSTRUCTION MANUAL
MANUEL D'INSTRUCTIONS
INSTRUCCIONES DE USO
BEDIENUNGSANLEITUNG
MANUALE D'USO
사용 설명서
使用説明書

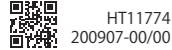
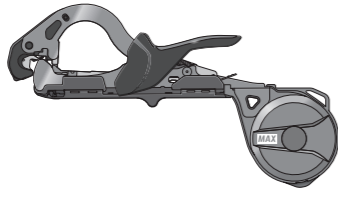

▲WARNING:

BEFORE USING THIS TOOL, STUDY THIS MANUAL TO ENSURE SAFETY AND FOLLOW WARNING INSTRUCTIONS. KEEP THESE INSTRUCTIONS WITH THE TOOL FOR FUTURE REFERENCE.

▲AVERTISSEMENT :

AVANT D'UTILISER CET OUTIL, ÉTUDIEZ CE MANUEL AFIN DE PRENDRE CONNAISSANCE DES AVERTISSEMENTS ET DES INSTRUCTIONS. CONSERVEZ CES INSTRUCTIONS AVEC L'OUTIL POUR TOUTE CONSULTATION ULTÉRIEURE.

▲ADVERTENCIA:

ANTES DE USAR ESTA HERRAMIENTA, LEA DETENIDAMENTE ESTAS INSTRUCCIONES Y ASEGÚRESE DE RESPETAR LAS ADVERTENCIAS DE SEGURIDAD. CONSERVE ESTAS INSTRUCCIONES CON LA HERRAMIENTA PARA FUTURAS CONSULTAS.

▲WARNING:

LESEN SIE VOR DER VERWENDUNG DIESES WERKZEUGS DIESE ANLEITUNG SORGFÄLTIG DURCH, UM DIE KENNTNIS DER SICHERHEITSWARNUNGEN UND ANWEISUNGEN SICHERZUSTELLEN. BEWAHREN SIE DIESE ANWEISUNGEN ZUM SPÄTEREN NACHSCHLAGEN ZUSAMMEN MIT DEM WERKZEUG AUF.

▲ATTENZIONE:

PRIMA DI UTILIZZARE QUESTO UTENSILE, STUDIARE IL PRESENTE MANUALE PER ASSICURARE LA COMPRESIONE DELLE AVVERTENZE DI SICUREZZA E DELLE ISTRUZIONI. CONSERVARE LE PRESENTI ISTRUZIONI INSIEME ALL'UTENSILE COME RIFERIMENTO FUTURO.

▲경고:

이 도구를 사용하기 전에, 이 설명서를 읽고 안전 경고와 지침을 확인하십시오. 나중에 참조할 수 있도록 이 설명서를 도구와 함께 보관하십시오.

▲警告:

●使用前請詳細閱讀說明書
●請妥善保管說明書，以便隨時查看內容

▲警告:

●使用前請詳細閱讀說明書
●請妥善保管說明書，以便隨時查看內容

SPECIFICATIONS / Caractéristiques / Spezifikationen / Presupuesto / Presupuesto / Specificazioni / 사양 / 產品規格 / 產品規格

Name / Nom / Nombre / Bezeichnung / Nome / 이름 / 產品名稱 / 產品名稱	HT-R45C(RD)	HT-R45L(OR)
Product code / Code produit / Código de producto / Produktcode / Codice prodotto / 제품 번호 / 產品編號 / 產品代碼	HT90125	HT90127
Dimensions / Dimensions / Dimensiones / Abmessungen / Dimensioni / 치수 / 外形尺寸 / 尺寸	148mm(H) × 353mm(L) × 37mm(W)	163mm(H) × 392mm(L) × 37mm(W)
Usable Staples / Agrafes utilisées / Grapas utilizadas / Verwendbare Heftklammern / Punti metallici utilizzati / 사용되는 스테이플 / 針種類 / 使用結束針	MAX STAPLES 604C-L, 604E-L	
Loadable Number of Staples / Nombre d'agrafes chargées / Número de grapas cargadas / Anzahl eingelegter Heftklammern / Numero di punti metallici utilizzati / 들어가는 스테이플의 수 / 可裝針數 / 可裝針數	MAX STAPLES 604C-L (200pcs / stick) 604E-L (172pcs / stick)	
Usable Tape / Bande utilisée / Cinta utilizada / Verwendbares Band / Nastro utilizzato / 사용되는 테이프 / 使用束帶 / 使用膠帶	MAX TAPE-10, 0.1mm T × 11mm W × 40m L (White) MAX TAPE-15, 0.15mm T × 11mm W × 26m L (Blue) MAX TAPE-25, 0.25mm T × 11mm W × 16m L (Red)	MAX TAPE-215, 0.15mm T × 12mm W × 55m L (White) MAX TAPE-225, 0.25mm T × 12mm W × 33m L (Blue)
Weight / Poids / Peso / Gewicht / Peso / 무게 / 重量 / 重量	450 grams	475 grams
Maximum Bundling Limit / Limite de liage / Limite de atadura / Bündelhöchstgrenze / Limite di legatura / 바인딩 한도 / 最大直徑 / 可結束最大直徑	Maximum 45mmφ	
Blade / Lame / Cuchilla / Klinge / Lama / 날 / 刀片 / 刀片	MAX CUTTER FOR TAPENER SERIES product code : TC90045	
Actual Staple Size / Illustration des agrafes à l'échelle 1 / Imagen de la grapa a escala completa / Abbildung einer Heftklammer im Originalmaßstab / Figura dei punti metallici in dimensioni reali / 스테이플의 실제 수치 / 結束針實物尺寸 / 結束針實物尺寸 (mm)	<p>604C-L</p>	<p>604E-L</p>

PARTS LIST / Liste des pieces / Lista de partes / Liste der Einzelteile / Elenco delle parti / 부품 목록 / 零件清單 / 零件清單

Index No.	Parts Code No.	Description
1	HT11778	B CASE S2(R45C)
2	FF31714	STRAIGHT PIN 1714
3	FF31712	STRAIGHT PIN 1712
4	KK33402	TORSION SPRING 3402
5	KK29192	COMPRESSION SPRING 9192
6	HT11768	LOCK PLATE S2(R45C)
7	HT11627	A CASE
8	CC43107	NAT M4(3)
9	AA05719	+PH TAP SCREW 3×8 (P)
10	HT11632	CLINCHER
11	HT11622	TAPE CATCH
12	HT11671	TAPE PLATE S
13	AA25537	SCREW BIND M4×6
14	HT11618	CLINCHER ARM
15	AA05716	SCREW BIND 4×6 (S-TIGHT)
16	HT11619	ARM SUPPORT
17	HT11637	B HANDLE
18	FF31713	STRAIGHT PIN 1713
19	HT11755	GRIP(R45C)
19	HT11769	GRIP(R45L)
20	KK13390	EXTENSION SPRING 3390
21	HT70106	MAGAZINE UNIT(R45C)
22	FF31716	STRAIGHT PIN 1716
23	HT11761	PUSHER(R45C)
24	HT11610	SPRING GUIDE ROD
25	KK29131	COMPRESSION SPRING 9131
26	HT11609	STAPLE COVER
27	TC90045	MAX CUTTER FOR TAPENER SERIES
28	KK34099	TORSION SPRING 4099
29	HT70070	TAPE GUIDE S UNIT
30	FF41740	STEP PIN 1740
31	HT11763	TAPE GUIDE SUPPORT S(R45C)
32	HT11781	TAPE GUIDE BASE S2(R45C)
33	FF31711	STRAIGHT PIN 1711
34	KK83018	CONICAL SPRING 3018
35	JJ10103	E-RING 3.2
36	HT11615	ROLLER
37	FF31643	STRAIGHT PIN 1643
38	FF31644	STRAIGHT PIN 1644
39	HT11754	DRIVER (R45C)
40	HT11788	A HANDLE S(R45C)
41	HT11603	TAPE SPRING
48	AA05715	SCREW BIND 4×16 (P)
50	HT70097	TAPE HOLDER ASSY(HT-S)
51	HT70107	BOBBIN CASE ASSY(R45C)

Index No.	Parts Code No.	Description
51	HT70109	BOBBIN CASE ASSY(R45L)
53	HT11669	RUBBER WASHER 1.7×6×2
55	HT11697	ARM SUPPORT S
57	HT70111	TAPE CATCH S2 ASSY(R45C)
58	HT81017	A HANDLE ASSY(R45C)
59	HT11762	BACKUP WASHER (R45C)
60	KK34101	TORSION SPRING 4101
61	HT11766	JAM CLEARING STICK(R45C)

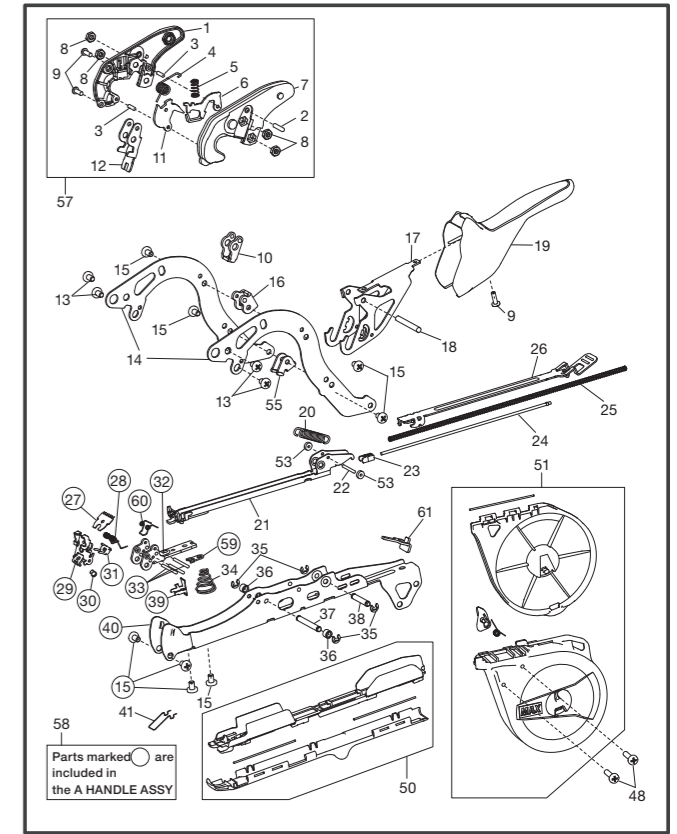

HOW TO USE / MÉTHODE D'UTILISATION / MODO DE USO / VERWENDUNG / MODALITÀ D'USO / 사용 방법 / 使用方式 / 使用方式

① How to Load Staples / Comment charger les agrafes / Cómo cargar las grapas / Einlegen der Heftklammern / Come caricare i punti metallici / 스테이플을 넣는 방법 / 怎麼安裝結束針 / 怎么安裝結束針

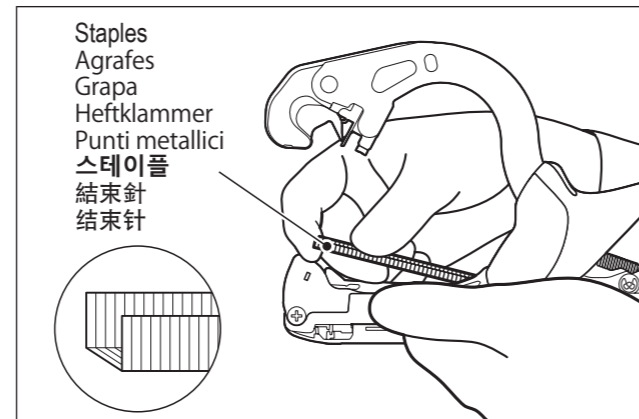
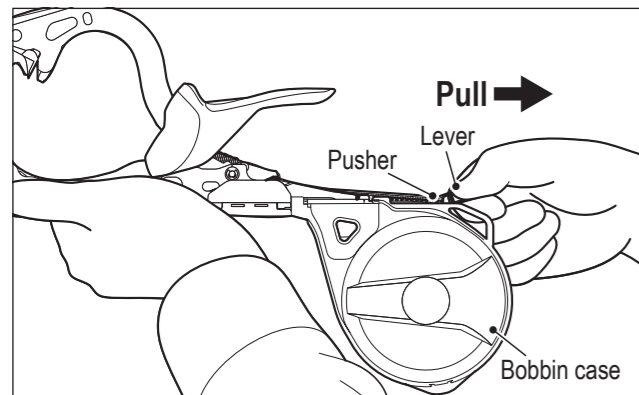
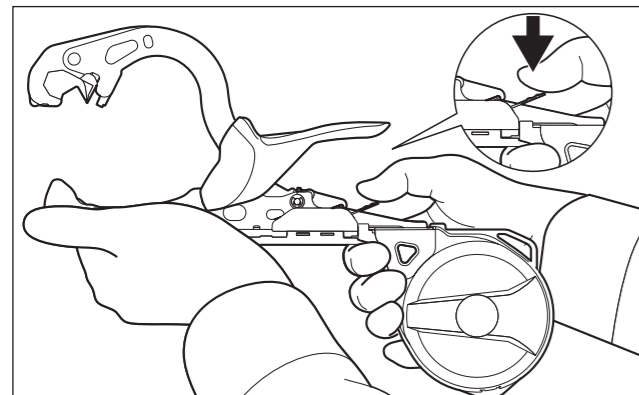

USE MAX STAPLES / UTILISER MAX STAPLE / UTILIZZA MAX STAPLE / BENUTZEN SIE MAX / USA MAX STAPLE / 맵크스의 스테이플을 사용하다 / 使用MAX結束針 / 使用MAX結束針

② How to Load the Tape / Comment charger la bande / Cómo cargar la cinta / Einlegen des Bandes / Come caricare il nastro / 테이프 넣는 방법 / 怎麼安裝結束帶 / 怎么安裝膠帶

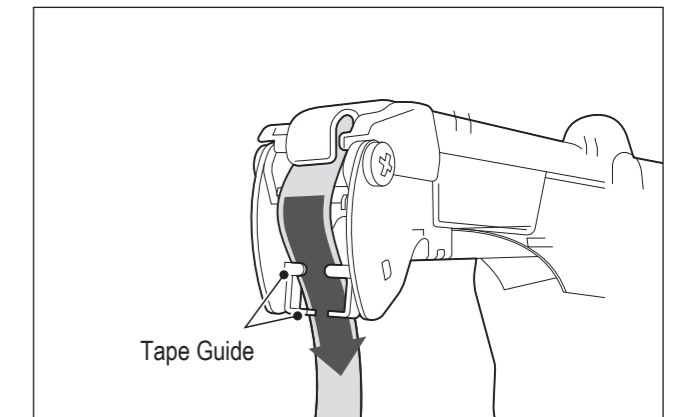
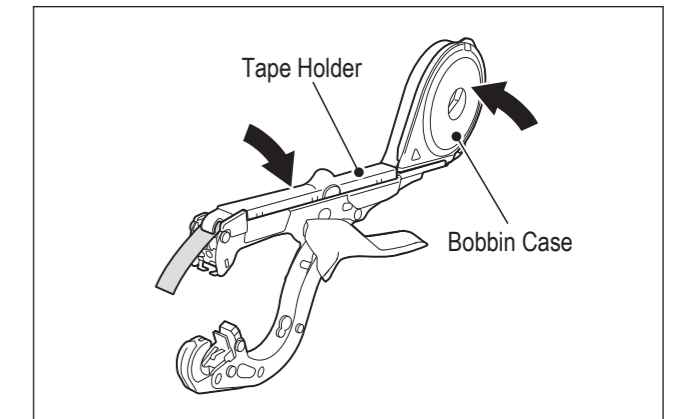
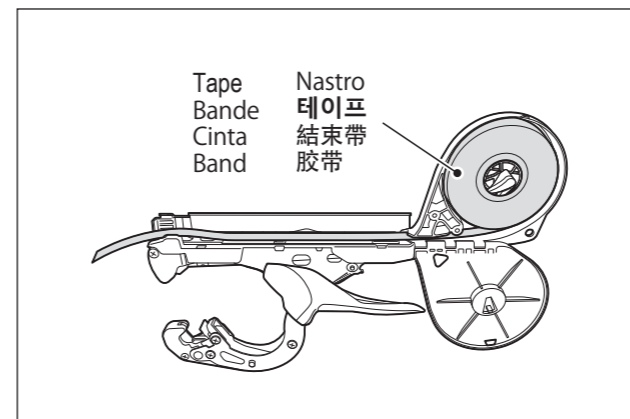
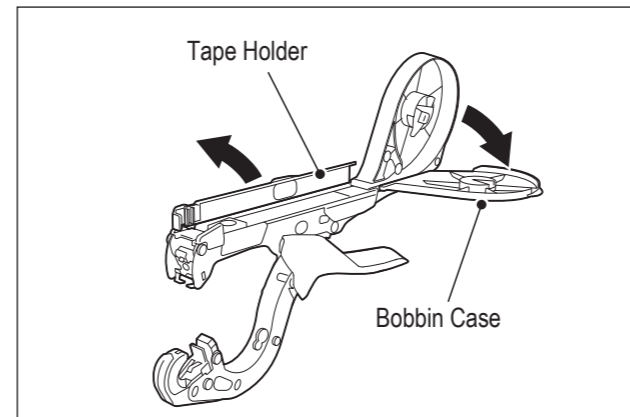

USE MAX TAPE / UTILISER MAX RUBAN / UTILIZZA MAX CINTA / BENUTZEN SIE MAX BAND / USA MAX NASTRO / 맵크스 테이프를 쓸 / 使用MAX結束帶 / 使用MAX膠帶

③ How to Bind Objects / Comment lier les objets /
 Cómo atar objetos / Zusammenbinden von Gegenständen /
 Come legare gli oggetti / 물건을 바인딩하는 방법 /
 結束方法 / 結束方法

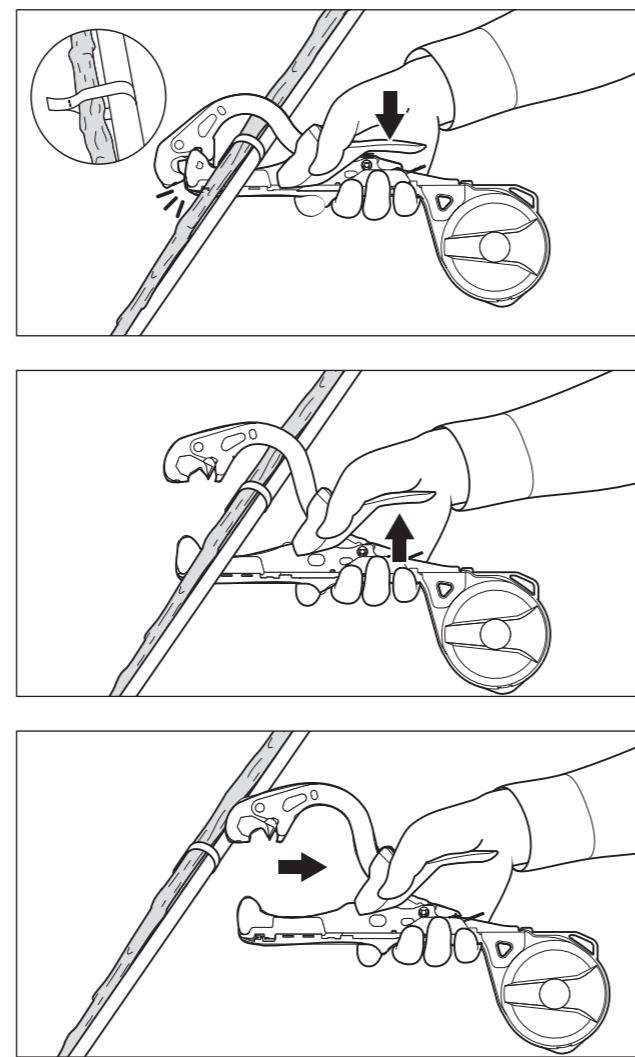
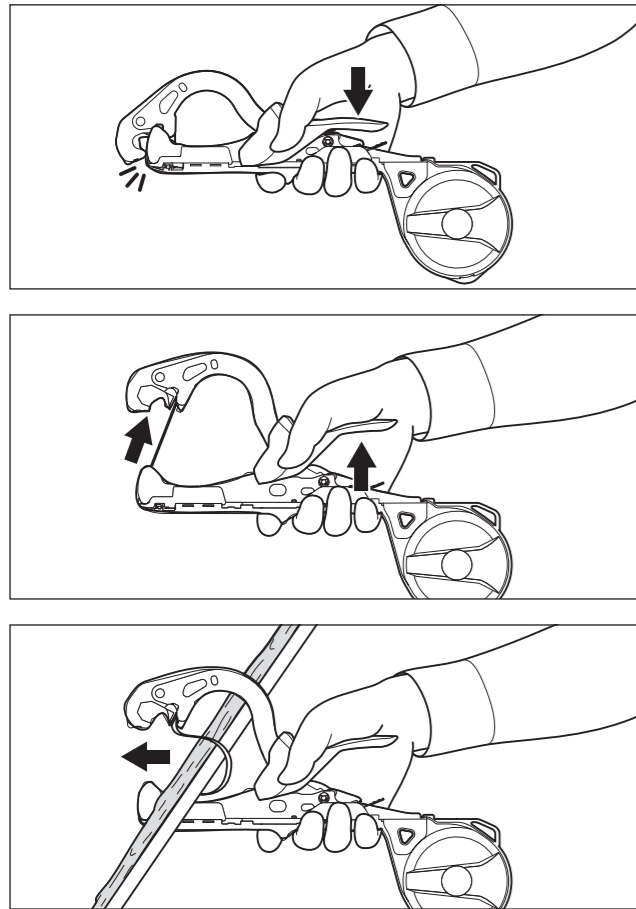

④ How to Change Blade / Méthode de rechange de la lame /
 Cómo cambiar la cuchilla / Auswechseln der Klinge /
 Come sostituire la lama / 날 교체 방법 / 怎麼更換刀片 /
 怎么更換刀片

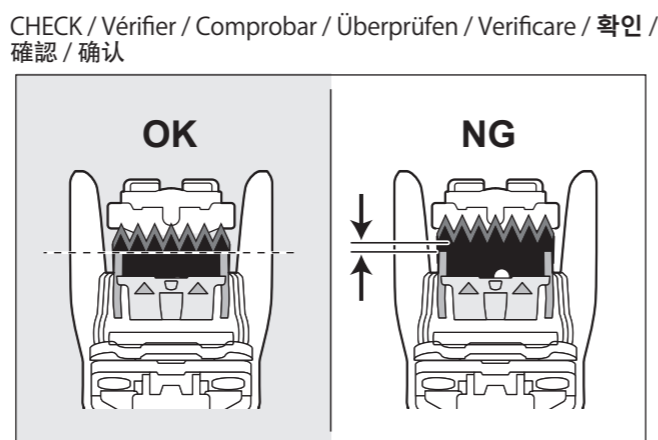
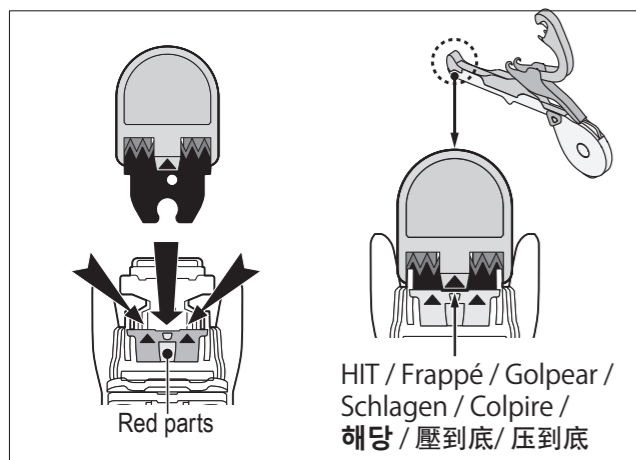
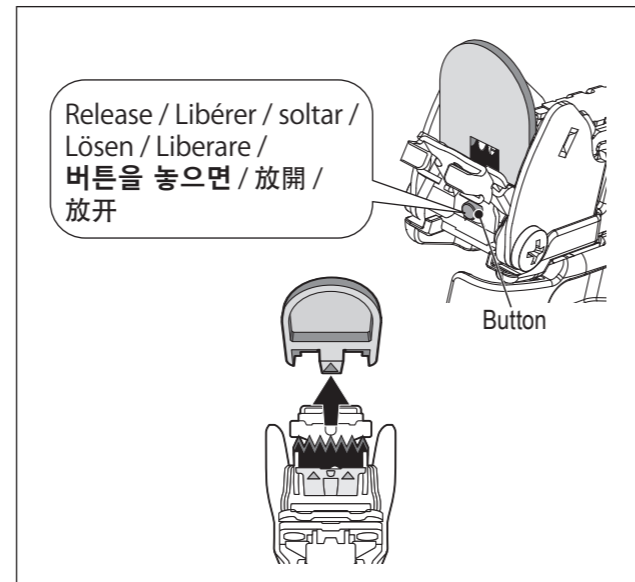
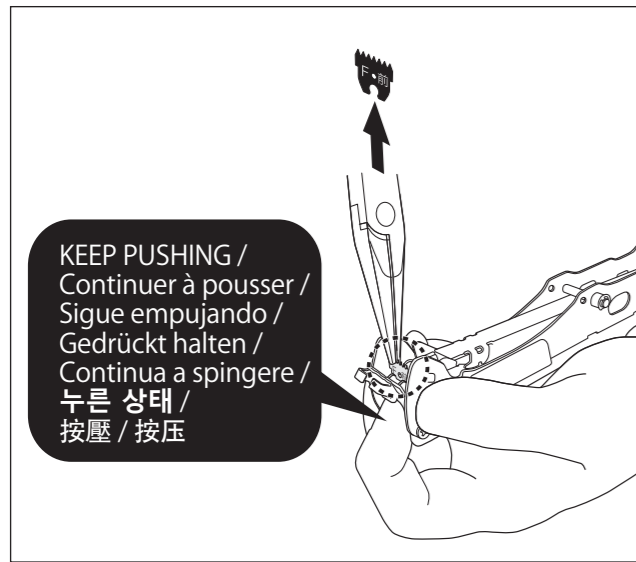
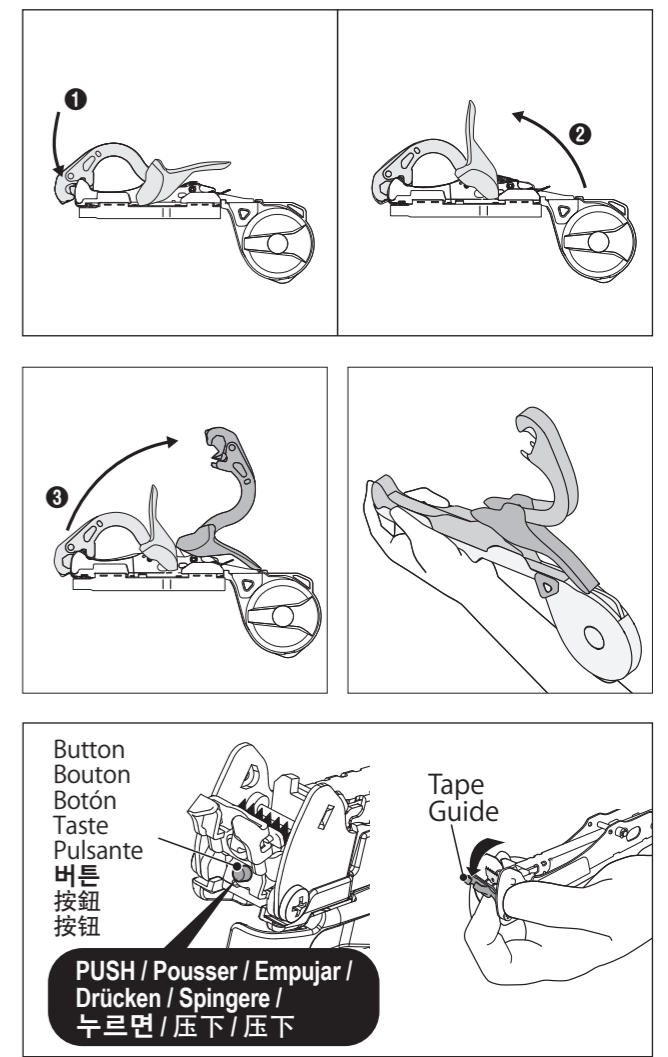
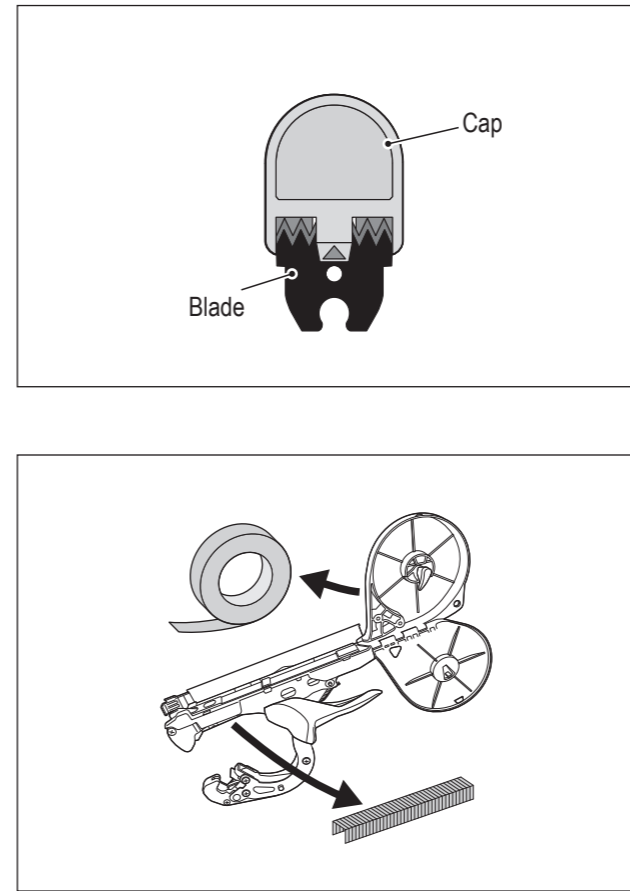

⑤ How to Remove Jammed Staples / Comment retirer des
 agrafes coincées / Cómo extraer grapas atascadas /
 Entfernen verklemmter Heftklammern / Come
 rimuovere i punti metallici inceppati / 걸린 스테이플을
 제거하는 방법 / 怎麼排出卡住的針 / 怎么排除卡住的針

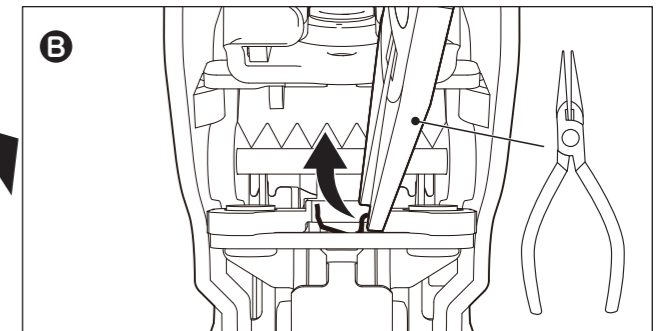
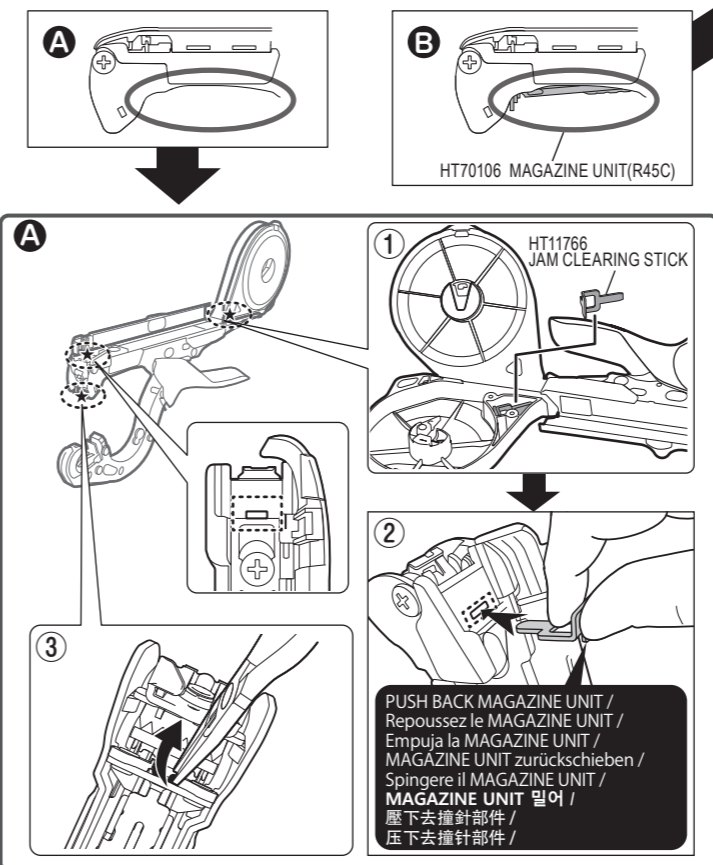

⑥ AFTER USE / APRÈS UTILISATION /
 DESPUÉS DEL USO / NACH DER VERWENDUNG /
 DOPO L'USO / 사용 후 / 使用後 / 使用後

Apply oil / Appliquer de l'huile / Aplicar aceite / Öl auftragen /
 Applicare olio / 주유 위치 / 添加潤滑油的位置 / 添加潤滑油的位置

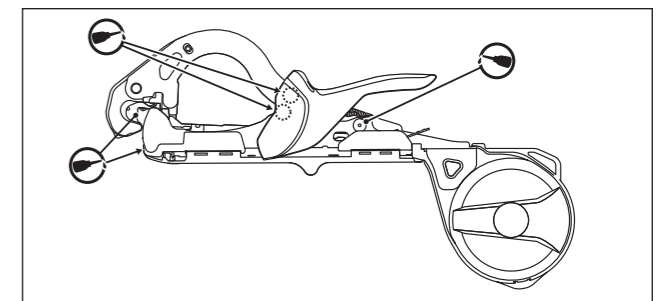

Turbin oils ISO VG32 /
 針車油 / 針車油